

2m cable  
optional Spiral cable 1-5m

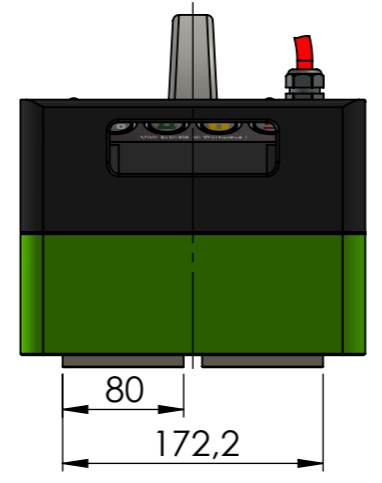

**Specification FXE 3200-80**

Nominative Force: 126kN		lifting capacity EN 13155/WLL	
Materialthickness >25mm (100%)		WLL= 3200kg	
15 kVA			
U: 380-480V Pulse		Protection Class IP 65	
R: 1,8Ω		Protectiv Earth SK I	
<b>Max. Load capacity at sheets and 4-edge pipes</b>			
T material thickness	Lmax (mm)	Wmax (mm)	Wll (kg)
>=8mm	2000	1500	600
>=10mm	2500	1500	900
>=15mm	2500	1500	1800
>=25mm	3000	1500	3200

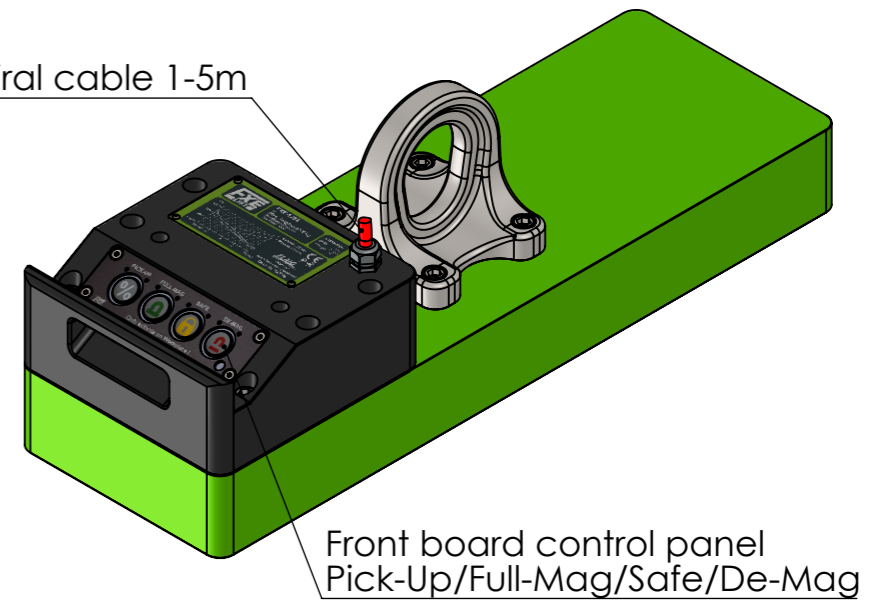
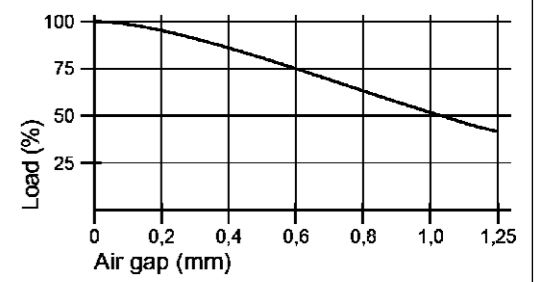
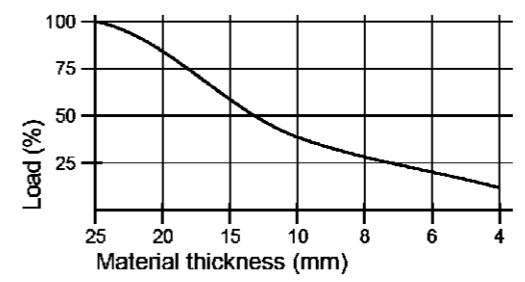

Schutzvermerk nach DIN ISO 16016 beachten! Nachdruck nur mit unserer Genehmigung!		3,2 / -0,05 / -0,2	tolerance	material:	weight: 120kg
All rights reserved according to DIN ISO 16016! Reprint with our permission only!			ISO 7168 M	drawing no.:	0018547
date	name	description: <b>FXE 3200-80</b>			
drawn 27.10.2023	TW				
edit 30.10.2023					
appr. 30.10.2023	TW				
rev. change date name		part no.:		sheet 1 / 1	
		10603202		A3	
		scale: 1:5		Status: Freigegeben	

